

The Forum

August 2017



Vol. 19, No. 8

Corn feed, hog roast, TGoM potluck, demonstrations...what more could we ask for at our Aug. 9 family and friends meeting?

Where: Dan Pate's shop on Minnesota HI way 56. Just three miles south of the Stanton airport at 357 th street. Dan Pate does auto development and restoration. Again, last year while we were cleaning up the mess on Thursday morning (Using a front end loader!) I asked Dan if he was willing to give it one more time. He is very willing. This will be the eighth time Dan and LuAnn have hosted the August meeting. This makes them even more a super hero team. If this announcement seems redundant; well, it just might be. Seven times this meeting has been a serious treat, weather and all. We should test the odds once more.

35730 Hiway 56 Blvd, Dennison MN 55018

Note: Right now the bridge is out one mile south of the Stanton airport. You have to approach from the South. That may change by 9 August but this is your warning.

Starting time: Dinner at 6:30. Set up starting is any time before noon. Jim Moenck, Gary Myers and Herb will be starting a fire about 9AM. I'm thinking it would be great if we ended up with a bouquet of calla lilies or roses by the time we do show and tell. We are trying to get people who are available to come early and enjoy the day. Tom and Wendy have already offered to trim trees and mow, and a bit more help would be very welcome. "This is part of what we mean by enjoy the day."

Features for the day:

Myron Hanson will host an open forge from 1 PM on. Come and make something. Tom Sheely will have some roses to mimic.

Jim Moenck is offering the demonstration of the heat treating of a knife blade. Jim has been working on his bladesmith certification and the effort will be fresh in his mind. It seems all new members want to make a knife and this is their chance to know more about what they are getting into.

Dan Pate is offering to demo any of his "skinny metal" machines during the afternoon. Those with an interest in metal shaping of materials thinner than 10 gage really should not miss this chance. Dan has a unique collection of ways to form metal sheets into almost anything you desire. He can demonstrate all of these and offers to take requests. Dan's equipment mix has changed again this year, so do not think that you have already seen it all. Dan often allows members to experiment with a machine. Your liability, you might learn to handle a machine that will shrink, stamp, fold, staple or mutilate 10 gage steel very carefully. (Someone usually demonstrates the effect of an "English Wheel" on a finger.) Safety officers take note!

This meeting features and is known as **The Corn Feed**. Dick Carlson has put his heart into this for years. Some of us have humbly joined in the effort. Herb plans to roast a hog. He does not promise to cut back a little on the garlic (unless someone has a good reason). He will probably go back to butter for basting. Once again a few chickens will be prepared for those who avoid pork. Recognize the chickens will be prepared by smoking and secondary roasting in the cavity of the hog. (Some have dietary restrictions.)

This is family and friends night. We have had some wonderful evenings at Dan and LuAnn's park like setting. Show and tell will be good. Do everything you can to be there. This is intended to be a very family friendly and social meeting.

When planning your contribution to the potluck please recognize that we will be a bit long on sweet corn and meat so think salads, breads, and desserts or whatever you think is special. As per last year, if you need a hint, Myron especially likes oatmeal cookies with lots of raisins.

Post note: Last year there were requests for smoked chicken to take home. They are not available on short notice. I think we can accommodate these needs (wants?) if you get your order to Herb at least two weeks before the meeting. These chickens are local, organic and smoked to order. They are not a commodity item. Am I making it sound like I enjoy this? Herb Fick

DIRECTIONS! (How to get there by avoiding the bridge that's out)

From the North focus on getting to Northfield, Stanton, or Cannon Falls. From Northfield take the road to Dennison instead of State Road 19 to Stanton. Three miles East of Dennison you find State Road 56. Just go North about two miles. From Stanton go West just over a mile. Goodhue Avenue goes South. It sort of parallels 56 mile to the Oxford mill road. Then south sort of following the main road until it turns into County 24. County road 24 intersects Hiway 56, then and go North on 56 two miles to Dan's.

What makes this important is that cell phone reception near Pate's dies out for most people. If lost try to call Herb (507 649 1611). We will get a few signs at the intersections.

Come early. Demos start around 1. Potluck meal is at 6:30.

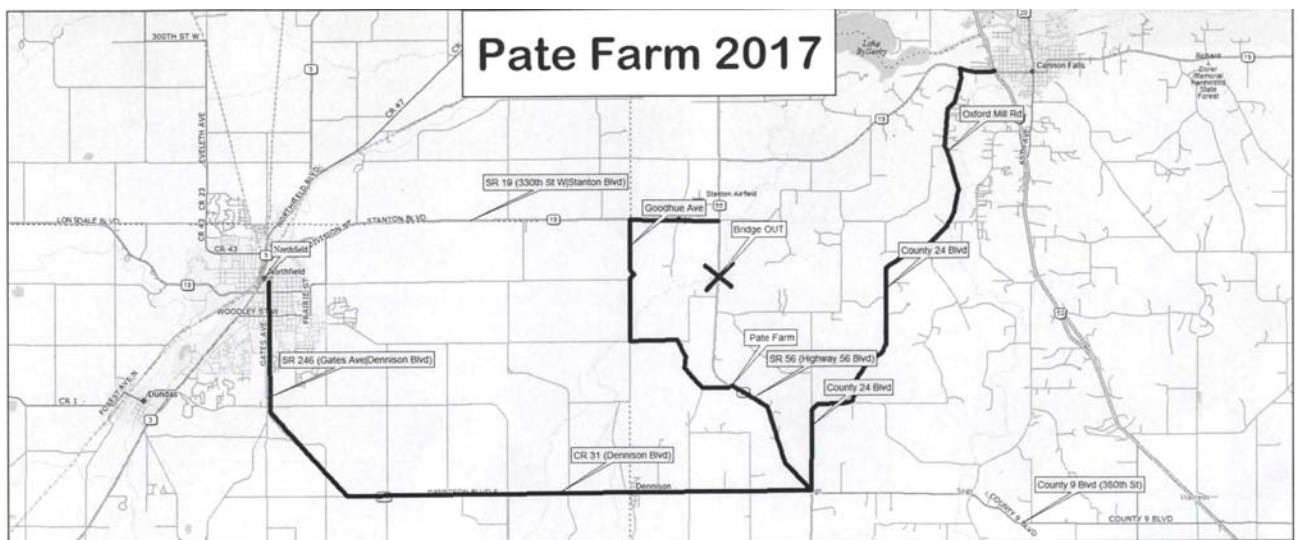

'The *MaDnEsS*' is just around the corner! September 15, 16, 17

Unless you just joined the Guild recently you should have already been feeling the pull towards Hastings. Yes, The Guild's Fall Conference, aka "The Madness," is approaching 15-17 September. Brochures should arrive in the mail shortly and will contain all the exciting details of demonstrators and events that will be there, but I wanted to make a quick plug of a few things you can and should already be doing to get ready.

Candle Holder Contest: This year's contest theme is candle holders. If you wish to compete, make a candle holder to donate to the Guild's Saturday auction. 1st place gets \$100, 2nd \$60, and 3rd \$40 but more importantly you get bragging rights for the year. Winners are determined by how much money they earn in the auction so yes, you can bid on your own piece to nudge it towards the winners circle. You can use any metal working technique you want; the only restriction is the finished piece has to serve as a candle holder. So start designing and making your winning piece now.

Found Art: This activity encourages people to turn interesting bits of metal into sculpture and is one of the most popular at the Madness, but it can't happen without those interesting bits of metal. So go through your shop and ask any appropriate businesses you may know to collect all sorts of stuff like odd shaped cut offs, gears, car and bike parts, springs, chains, screens, broken tools, etc. Almost anything not fit for other uses can find a purpose here. Of special interest is silver flatware. We almost ran out of this popular material last year so keep your eyes out for any you can get for cheap or free.

The Silent Auction: The silent auction is annual proof that one Guilders trash is another's treasure as surplus materials, old tools, and other oddities that you might have been stubbing your toe on for years can be the object of a bidding war between fellow metal junkies.

The Live Auction: The live auction is for higher end items, works made by Guilders and displayed in the gallery, new gear donated by Guild sponsors, a surprising amount (though never enough) canned goods, etc. If you know a metal related business you might consider explaining what we are about and asking for a donation to the auction in exchange for a tax deduction (we can provide the form) and publicity with our group. Also please consider making an item or two for the Guild to auction off after display in the Gallery.

Meals: If you plan on signing up for the meal plan for the conference please send that and your registration in early. We don't want anyone to go hungry but need to let the cater know enough in advance how many people to plan for.

— Martin Pansch

2017 Pre-Conference 1-Day Workshop with Steve Mankowski & Shelton Browder

Date and time: Friday, Sept. 15, 2017 9:00-5:00

Instructors: Stephen Mankowski & Shelton Browder

Fee for Class: \$135.

Class size: Maximum students: 16 Minimum students: 10

Location: Little Log House Village, Hastings, MN (map at right)

Tools and Equipment or other items participants are to bring to the class. forge, anvil, basic tools - specific tools for the project will be listed in an acceptance letter

Special Instructions: stock & coal will be provided

Class Description: Steve Mankowski and Shelton Browder have shared blacksmith experience at historic Colonial Williamsburg in Virginia, demonstrating traditional methods to make tools and household items of the period. At this year's one-day pre-conference workshop, students will have the opportunity to make a small hand axe (including making the drift for the eye), a chisel and/or a gouge.



Students will need to bring their own forge, anvil, safety gear and tools (a few specific to these projects will be listed in the acceptance letter). Stock and coal will be provided. Students should have experience working with tool steel and forge-welding. Set up indoors, in the main demonstration building. The workshop will run from 9:00 to 5:00, with a lunch break (students, bring a lunch).

Plan to stay for the evening gala, which includes the gallery opening and a video presentation of "Ore to Axe," documenting the process of extracting iron from earth using the bloomery method of smelting, converting iron into steel and then forging an axe. Steve and Shelton will be on hand to share their experience and answer questions.

To register, send a check for \$135 made out to "The Guild of Metalsmiths" and mail it, along with your contact information, to:

Christina Dodge
4430 Lyndale Avenue N
Minneapolis, MN 55412

Priority will be given to Guild members, acceptance based on the postmark date, and will be acknowledged with an email or letter.

General questions should be directed to:

Larry Wasmund
(507) 469-0205
poundedtreasures@gmail.com

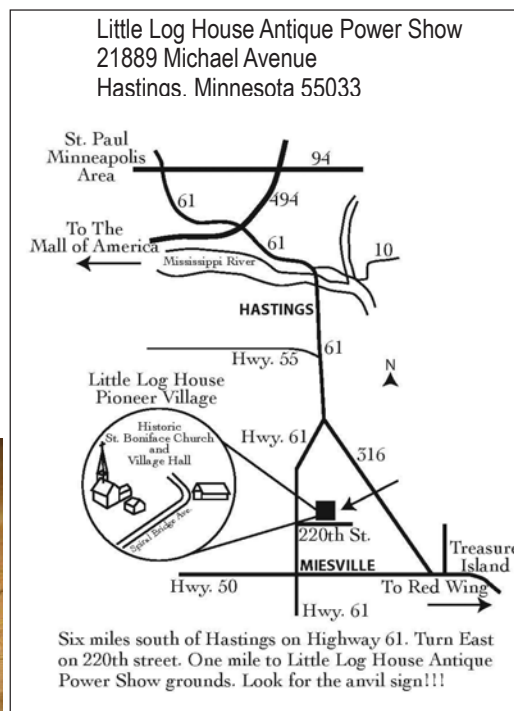

Our neighborhood of smiths

The Guild of Metalsmiths (TGoM)

All membership meetings are the second Wednesday of February, April, June, August, and October, except December. For these meetings a potluck meal begins at 6:30 pm and the business meeting begins at 7, with a demonstration or activity starting around 8 (times approximate). To check your membership expiration date, see the mailing label on your latest copy of "Metalsmith."

President: Martin Pansch Vice-President: Rick Wessling
blacksmithingyeti@gmail.com rgwessling@gmail.com
612-599-4762 612-875-4420
Our website is: <http://www.metalsmith.org>

Badger Blacksmiths meetings

Our contact information is as follows:

President: Don Hogenson Newsletter editor: John Grump
715-265-4701 715-835-0894
johngrump@att.net

Lake Superior Metalsmiths

Lake Superior Metalsmiths (LSM) meet the fourth Saturday of the month. Potluck at noon with meeting to follow.

Contacts are:

Charley Brown, President, CharleyRB@charter.net, 218-428-7906
Dave Hanson, VP, duluthblacksmith@yahoo.com, 218-391-4466

Northern Minnesota Metalsmiths

The NMM meets the first Monday of the month at Lake Itasca Region Pioneer Farmers (LIRPF) show grounds, 1/4 mile east of the north entrance to Itasca State Park.

Contact Keith Johnson for monthly specifics at keith@greatriverforge.com. The NMM's website is www.nmmetalsmiths.org

Central Minnesota Blacksmiths (CMB)

Meet on the first Monday of each month. Potluck followed by demo. Locations are different every month so please call or write for info

President: Ken Zitur Brian Johnson
320-746-8161 16777 Co Rd 75 NW
mail@kensiron.com Clearwater MN 55367
320-558-6898

Chicago Avenue Fire Arts Center (CAFAC)

Quarterly blacksmithing classes, exhibits, and open house events
www.cafac.org email: info@cafac.org

Tunnel Mill Crafts

Blacksmith shop, traditional iron work, classes
4505 Highway 63 North, Rochester, MN 55906
507 289-4189 or 507 289-5246

John & Carol Adams jc-adams@msn.com,
<http://www.tunnelmillcrafts.com/>

New TGoM Members for August 2017

Russell Bartling, Sand Springs, AZ
Autumn Dupaul, Coon Rapids, MN
Alexander Rachner, Cottage Grove, MN
Chad Krzmarick, Roseville, MN
Espen Dolezal, Minneapolis, MN
Brett Perrson, Buckeye, AZ
Douglas LaBorde, Pierz, MN

Power Hammer Use Class with Nathan Robertson **IS FULL!**

Date and Time: Saturday and Sunday, September 9 & 10, 2017. Start time 9:00am

Location: Pansch Farm, 8750 Yale Ave, Young America MN

Box Tongs Class is **Cancelled!**

Saturday, August 4, 8:30 am to 4:00 pm

Location: 28275 464th Street Cleveland MN. 56017

Fall Conference Family Activities

Contact is: Sheri Stanaitis

home (715) 698-2895

cell (715) 307-3544

spaco@baldwin-telecom.net

Build and Bake in a Portable Brick Oven

9:00 am – 5:00 pm Saturday, September 16th

Join David S. Cargo to learn how to build a portable stacked-brick oven. After the oven is built, it will be fired up while students learn how to make dough for flatbreads, pizza, and bread. Bake all these in the brick oven and then eat them.

You will leave with knowledge of building stacked brick ovens, plans for three different sizes of ovens, and practice in baking in these ovens.

Class runs from 9 am – 5 pm with a 1 hour break starting at noon for students to have lunch.

Class cost is \$40.00

Class size: maximum of 15 students/minimum 5

Must be registered by Sept. 9th

Students should bring hat, gloves, note-taking materials and sturdy shoes (in case of falling bricks).

Make Checks payable to: David S. Cargo.

Mail Checks to: Sheri Stanaitis, 2476 10th Ave., Baldwin, WI 54002. Call Sheri at: (715) 698 - 2895

Magnetic Art

Design and build magnetic/ferrous creations. **Free all weekend!!**

Found Art

Herb Fick and company will weld whatever you find on the trailer into your art creation.

Free. Found Art closes at 4:00 pm Saturday!

Belt Grinder Class

The 72 inch belt grinder class is moving along. We plan on having multiple classes late fall and into winter depending on the number of students. at the Jackson Street Roundhouse. This design does not include a motor or pulleys. Cost is \$325 or you can buy just the 4 wheels for \$175. Payment must be made by the end of the fall conference September 17 so we can order supplies.

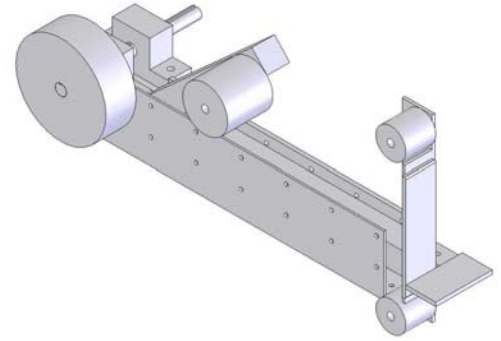

Send checks made out to Gordon Barr:

Gordon Barr
11021 27th Ave
Burnsville, MN 55337
agbarr@aol.com

Beginners Blacksmithing Classes 2017 / 2018

- Registrations will begin and dates will be announced for the level 1 beginners September 1, 2017
- Registrations will begin and dates will be announced for the level 2 beginners December 1, 2017
- Registrations will begin and dates will be announced for the beginners projects December 1, 2017

In an effort to give more new blacksmiths an opportunity to learn how to forge steel, the Beginning Blacksmith class format has been modified and split into three separate classes. Students will need to sign up for each level separately. It is recommended that first time students begin with level 1, then level 2, then project classes before taking more advanced classes offered by the Guild (hammer making, tongs, struck tools, etc.). This path provides a common background skill set and terminology to improve the effectiveness of advanced classes. Students with prior experience can judge their proficiency and take the appropriate classes.

Beginner Level 1 (offered Sept/Oct/Nov) is a 2 day class covering the basics of: Safety, Tools, Fire Control, Forging Dynamics, Tapers (ribbon, fishtail, point), Twisting, Riveting, Shouldering, Upset, Cutting, Splitting, Punching

Beginner Level 2 (offered Dec/Jan/Feb) is a 1 day class covering Heat Treat, Scrolling, Bending, Forge weld

Beginner Projects (offered Jan/Feb) is a 1 day class featuring a project such as Forge Tools (rake, poker, shovel, watering can), Hooks, Bottle Opener, Wall Sconce, Tongs

Cost: (covers everything you need, the facility, coal and metal)

Level 1 (2 day) \$120 for members, \$130 non members

Level 2 (1 day) \$60 members, \$65 non member

Beginner project (1 day) \$60 members, \$65 non member

The optional printed out workbook/study guide is \$15 (available free on line)

Minors (under 18) can share a forge with a guardian for an additional \$10 /day

Location:

The classes are held at the Minnesota School of Horseshoeing, 6250 Riverdale Dr NW, just off Hwy 10 in Anoka near the Anoka Vocational College and in Cleveland, MN near Mankato.



2017 TGoM 'Rest of Summer' Demo Calendar

The chart below shows August and September demonstration opportunities for Guild members. Contact people and information are listed, as well as locations and dates of events. If you are looking at this chart online, the email links should work if you click on them. If you have difficulty reading this chart, the events are also available on our website in the "Meetings/Events Calendar" pages here: <http://metalsmith.org/events/> These demos are good opportunities for our smiths who need some experience, who want to put their skills to work, and who are willing to share their knowledge with the public. It's a good application of our educational mission.

18-20 AUG 2017	Butterfield Threshermen's Assn. Steam & Gas Engine Show	Butterfield, MN	Larry Wasmund	poundedtreasures@Gmail.com	651-322-6626	Blacksmithing and Bronze casting. All sales go to the show.
25-27 AUG 2017	Pioneer Power Show	Le Seuer, MN	NA	NA	NA	Not open to casual demonstration but go watch Wyatt, Jim and others demo.
1-3 SEP 2017	Rice County Steam and Gas Engine Show	Dundus, MN	Myron Hanson	None	651-454-3984	Bring your hand tools and a project.
8-9 SEP 2017	Lamberton Hot Iron Days	Lamberton, MN	Bob Brown	Bbrown474@msn.com	651-457-0086	Blacksmithing demo help welcome all Saturday Friday: mould making Noon-7pm. Iron pour at 10PM Saturday: mould making 8am-11am. Iron pour at 4pm.
9-10 Sep 2017	Laura Ingalls Wilder Days	Pepin, WI	Tom Latane	tlatane@centurytel.net	715-442-2419	Enough blacksmith demonstrators currently. Other period craft demonstrations welcome. Call/email Tom for details.
Wednesdays, Saturdays, Sundays	Jackson Street Roundhouse	St. Paul, MN	Gordon Barr	agbarr@aol.com	952-894-4821	Two forges and anvils available for use by Guild members on personal projects. Occasional visitors to demonstrate to.
Most weekends Memorial Day through Labor Day.	The Landing	Shakopee, MN	None - Contact site manager Rich Williams	Rwilliams@threeriversparkdistrict.org	763-694-7784	Costume needed (overalls and white button up shirt okay).

Jackson Street Roundhouse Ongoing Demo Ops

- June, July, August - Wednesday, Friday, Saturday 9-4
- September - Wednesday and Saturday 9 - 4

You can enter through the back gate. We now have a second forge set up outside. People that would like to work in the blacksmith shop these days are welcome to drop by. Any questions, call Gordon Barr 612-242-5827

Nowthen Threshing Show Demo Op

Remember to come to the Nowthen Threshing Show to demonstrate blacksmithing. All levels of experience are welcome. The dates are Friday August, 18 through August 20, 2017. Come to the August 9 Guild meeting at Dan Pate's to sign up for a time to demonstrate and receive a free pass. If you will not be at the August meeting, send an email to bfredell@msn.com and I will mail to you a pass and a map to the show grounds. State the dates you wish to demonstrate.

— Bob Fredell

Note: The information below is provided as a service for TGoM members. Members may submit items for sale and upcoming events that are considered relevant to our group, and they will be published as space permits. The Guild of Metalsmiths is not responsible for these items or events.

The Chicago Avenue Fire Arts Center presents...

HOTHOUSE RODEO

A Fire Arts Extravaganza featuring workshops, demonstrations, an art market, entertainment, food & refreshments!

September 22, 23 & 24

Friday: Forging animal heads with Jim Ricci
 Making cuttlebone molds for pewter casting
 Making scratch molds for bronze casting with the CAFAC foundry team
 Art market

Saturday: Forging bottle openers with Brad Buxton
 Casting pewter cuttlebone molds with Jess Bergman Tank
 Art market

Saturday night: Open (Hot) House with CAFAC instructor demos, bronze pour and fire performers

Sunday: Neon with Jon Ault

More details and workshop registration at www.cafac.org/events
 Chicago Avenue Fire Arts Center, 3749 Chicago Ave, Minneapolis
 Vol 19 Issue 8 August 2017

Tunnel Mill Crafts

We are located in southern Minnesota. Tunnel Mill was an old water powered mill. Built in 1869. Retired in the late 1920's.

Located on Bear Creek north of Spring Valley, MN.

Wooded 50 acres with a stream that runs through it. Now, it's a place for crafts people and friends to congregate, relax and learn some of our forgotten crafts.

2017 classes & events

Ric Furrer August 18, 19, 20, 2017

Making damascus (layered steel). Check out our website for more information: www.tunnelmillcrafts.com

Check out Ric Furrer at <http://www.doorcountyforgeworks.com/>
 Watch the video at <http://www.youtube.com/user/RicFurrer>

Fall Gathering at the Mill Oct. 6, 7, 8

Visit our website for full details on this year's get-together:
<http://www.tunnelmillcrafts.com/Calendar/Calendar.htm>

Contact us for more information...jc-adams@msn.com or 507-289-4189. Hosted by John & Carol Adams.

THE GUILD OF METALSMITHS, Board of Directors – July 12, 2017

Held At: Danish American Center, 3030 West River Parkway, Minneapolis

Call to Order: 7:08pm by Martin Pansch. Members in attendance: Barr, Bettenberg, Dodge, Gavin, Lockwood, Pansch, Phillips, Sheely, Wasmund, Wessling, Widenhofer. Missing: Visitor(s): Ryan Goeken, Tom Steinke, Wendy Anderson. Approval of previous meeting's minutes: Motion to accept by Wasmund, second by Gavin. Motion passes.

COMMITTEE REPORTS:

Treasurer Report: Grace Sheely

Spent \$4,000 on grants class. Revenue from class will go back into grants fund. There are many delinquent members at this time. Decided to keep current checking system until new treasurer is on board.

2017 BALANCE SHEET	31-May-16	30-Jun-16
CASH ASSETS		
Wells Fargo Checking Balance	\$ 18,645.53	\$ 16,047.92
Wells Fargo Savings Balance	\$ 26,780.65	\$ 26,781.31
Wells Fargo Simple Checking	\$ 16,344.59	\$ 16,634.99
Sub-Total Cash	\$ 61,770.77	\$ 59,464.22
Reserved for Grants Funding	\$ 7,988.76	\$ 4,289.11
TOTAL CASH ASSETS	\$ 53,782.01	\$ 55,175.11
REVENUE		
Deposits Bank	\$ 369.68	\$ 1,280.66
Deposits Paypal	\$ 203.28	\$ 290.40
TOTAL REVENUE	\$ 572.96	\$ 1,571.06
EXPENSES		
Membership		
Education	\$ 1,361.71	\$ 3,776.93
Communications	\$ 2,351.97	\$ 32.68
Program		\$ 68.00
Program Conference Management	\$ 101.19	
TOTAL EXPENSES	\$ 3,814.87	\$ 3,877.61
NET GAIN/LOSS	\$ (3,241.91)	\$ (2,306.55)

PAID MEMBERSHIPS

11

Membership Services Committee: Chair Barr.

600 names sent out for conference, 413 July Forums sent out, 300 current membership. Hopefully new database will help take care of this lag. Status on updating membership database-covered later in meeting

Education Committee report: Chair -Wasmund, Vice Chair- Bryan Carlson

Report on Mark Asprey class/future intermediate classes- Class went very well at Nowthen. Students know that they will be teaching a class in 2018. Status of schedule-finishing up schedule in Aug. schedule is mostly set. Report on Nowthen Hammer-in-Hammer-in went well, planning for 2018 bigger hammer-in

Program Committee: Chair-Lockwood, Vice Chair- Vacant

Meeting at the Landing went well, smaller than expected. Tunnel Mill event went well. Status of August, October meetings-August meeting at Dan Pate's-Look for map to Dan's in Forum-road closings will make route there different than in the past. Make For All is a tentative meeting spot for Oct meeting. Conference status-Brochure is coming along-almost ready to go. Pansch will be sending out an email to broaden advertising of event. Food services will be the same as previous year

Communications Committee: Chair-Bettenberg, Vice Chair- Vacant

Membership survey is almost ready-plan is to be ready to hand out by Aug. meeting. Banners and brochures have been going out to demonstrators. Status of simplified brochure-brochure is done. Status of Metalsmith handoff-Allysa Sodeberg (sp?) will be taking over Metalsmith duties. Status of webmaster handoff- Ryan Goeken will be taking over as webmaster and is looking forward to upgrading systems.

UNFINISHED BUSINESS:

New Membership Database- Goeken will be upgrading database. Credit Card payments for classes, membership and conference. Tabled w/ addition of new webmaster. Discussion of Guild positions that need to be filled and prioritization. What should be pushed for next? Treasurer-may need new "food guy/gal"/buffet marshal and co-chair for program committee.

Long Range Planning.-Book ideas for Iron Menagerie II, Pop-up craft show/fairs in conjunction with teaching

NEW BUSINESS:

Request from Education to purchase two header blocks for future Intermediate classes (\$400). Phillips moves, Gavin 2nds-Motion passes
Request to purchase new layout software for Metalsmith editing (est \$700-1300). Proposed ad hoc committee to look at demonstration of software. Gavin motions, Phillips seconds. Motion passes. Bettenberg discusses money for new software. Lockwood motions to approve up to \$1000 annually for software. Phillips seconds. Motion passes. Discussion-Replacing trailers-what size is needed? What are the costs? Decision made to assess value/condition of trailers. Discussed finding room in by-monthly trailer by removing some un-needed items.
New Guild signs: Steinke and Anderson will be making new "anvil" signage. Discussion on what do we need in signs, sizes, visibility, etc. What worked with old sign, what could be improved, what didn't work? Designs will be created and submitted. Disc. New canopy for demonstrators

ADJOURNMENT: 10:06pm Submitted by Paul Widenhofer, Recorder

Goings on...a listing of TGoM events at a glance



- All membership meetings are the second Wednesday of February, April, June, August, and October. Date for December will be announced. For these meetings a potluck meal begins at 6:30 pm and the business meeting begins at 7, with a demonstration or activity starting around 8 (times approximate).
- Education Comm. meets first Wednesday of each month. Contact Larry Wasmund, chair: poundedtreasures@gmail.com
- Program Comm. meetings are 7 pm the third Thursday of each month. Mark Lockwood is chair: mark.lockwood@daikinapplied.com
- All board meetings are the second Wednesday of January, March, May, July, September, and November. Potluck meal begins at 6:30, with meeting starting at 7 pm.

Events in August 2017

- August 4, Box Tongs Class, Cleveland MN, **CANCELLED**
- August 4-6, Scott/Carver Threshing Show, demo op.
- August 9, TGoM membership meeting, Dan Pate's estate
- August 11-13, Almelund Threshing Show, demo op.
- August 16-19, Murray County Fair, demo op.
- August 18-20, Nowthen Threshing Show, demo op
- August 18-20, Butterfield Steam & Gas Engine Show, demo op.
- August 25-27, Pioneer Power Show, LeSeuer, demo op

Events in September 2017

- September 1-3, Rice County Power Show, Dundas, MN-demo op
- September 8-9, Lamberton Hot Iron Days, demo op
- September 9-10, Power Hammer Use Pre-Pre-Conference Class **IS FULL!**
- September 9-10, Laura Ingalls Wilder Days, Pepin WI
- September 15, Pre-Conference Class, Little Log House
- September 15, 16, and 17, TGoM Annual Fall Conference, Little Log House

Events in October 2017

- October 11, TGoM membership meeting, no details yet.

Map to MN School of Horseshoeing

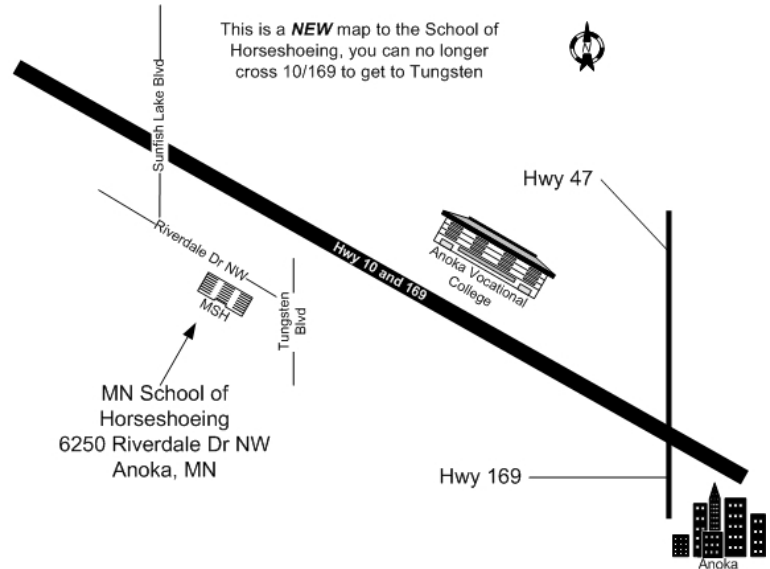

Join The Guild of Metalsmiths

Send \$30 dues to the address below. Please circle if you want to be listed in our membership directory and/or check items you don't want listed.

The Guild of Metalsmiths
PO Box 11423
St. Paul MN 55111

List Me
in the directory
but don't list

Don't List Me
in the Directory

address - phones: home - work - fax - cell - email - web page
(circle items above you DO NOT want published)

Name: _____

Email address: _____

Address: _____

City, State, Zip Code: _____

Primary phone: _____ Secondary phone: _____

All memberships are family memberships. Persons of all ages, professionals and hobbyists, are invited to join. We do not sell our mailing list.

ELECTRONIC FORUM

If you have not been receiving an email notification that The Forum is available, please verify that we have your correct email address. Contact Gordon Barr at agbarr@aol.com.



Address Service Requested

Forum deadline for September 2017:: Monday, August 21, 2017.

The deadline for content in The Forum is usually the third Monday of the month. Please send items to **Georgia Myers**, editor, by email to: gldmyers@embarqmail.com

The Guild of Metalsmiths on the web

Visit our website at <http://www.metalsmith.org>

Looking for something? Try the search engine. On our home page, at the top of the right sidebar, enter your query and click on "Search."

August 2017

Your membership expiration date will show on the address label of your quarterly Metalsmith magazine.

TGoM now accepts Paypal and most major credit cards

The Guild accepts Paypal and most major credit cards, in addition to paper checks, for the payment of annual dues. This should make it more convenient for members to pay dues.

The Guild of Metalsmiths, St. Paul, MN, publishes The GoM Forum monthly. It is intended as a tool to further our educational mission, to keep members up to date on current happenings, to publicize projects and workshops, a place for all members to express their opinions, concerns, learn more about each other—in short, to help us run our organization.

Information in this publication is provided as a service for our members. Members may submit items for sale and upcoming events that are considered relevant to our group, and they will be published as space permits. The Guild of Metalsmiths is not responsible for these items or events.

Guild educational grants

There is grant money available for Guild members to study intermediate and advanced metalworking techniques.

The Guild educational grant program is designed to bring new skills into the metalworking community. Participants are given money to pay for a portion of their expenses and are expected to learn some new or poorly understood skill, and then to share what they have learned with other members and the public through an article in our quarterly magazine, "The Metalsmith." They're also expected to lead a workshop on the topic (or other educational service approved by the board).

Application forms are available from the president or treasurer at a regular meeting, or by sending a self-addressed, stamped envelope to:

The Guild of Metalsmiths
PO Box 11423
St. Paul MN 55111